

Become an agile and international company!
成为敏捷化的国际性公司!

浙江日发纺织机械股份有限公司
ZHEJIANG RIFA TEXTILE MACHINERY CO.,LTD

Add: No.88 Woxi Avenue, Meizhu Industrial Zone,
Xinchang, Shaoxing, Zhejiang, China (312500)
地址: 浙江省绍兴市新昌县梅渚工业区沃西大道88号

安徽日发纺织机械有限公司
ANHUI RIFA TEXTILE MACHINERY CO.,LTD

Add: No. 1755, Changzhou Road (South), Industrial
Transfer Demonstration Region, Dangtu town, Ma'anshan
city, Anhui province, China (243000)

地址: 马鞍山承接产业转移示范园区常州南路1755号
电话(Tel): 400-999-8008 / 86-555-6680873
传真(Fax): 86-555-6680863
www.rifatm.com



本样本仅供参考, 不作为技术验收的依据。
为提高产品质量, 本公司保留更改规格之权力, 恕不另行通知。
This sample is used for reference only and is not serving as a basis for technical acceptance.
For the purpose of improving product quality, our company reserves the right to change product specifications without notice.



SPINNING Solutions

纺纱解决方案

RFRS51 转杯纺纱机

RFRS51 ROTOR SPINNING Machine



关于日发纺机

浙江日发纺织机械股份有限公司成立于2002年，注册资金6948.7万。公司系国家重点高新技术企业，国家机械工业重点骨干企业，国家863计划CIMS工程示范企业，全国CAD应用工程示范企业，国家火炬计划重点高新技术企业，中国纺织机械协会副会长单位。现旗下控股山东日发纺织机械有限公司、安徽日发纺织机械有限公司、浙江日发纺机技术有限公司。

公司以成为“敏捷化的国际性公司”为愿景，以“为用户提供智能纺织装备系统解决方案，并协助用户逐步实现数字化工厂”的梦想”为使命，致力于机电行业的“数字科技”，已成为国内外享有高知名度的纺织设备生产企业。二十几年来已成功开发了清梳联、并条机、转杯纺纱机、喷气涡流纺纱机、倍捻机、直捻机、假捻变形机、精密并纱（络筒）机、自动穿经机、喷气织机、喷水织机、剑杆织机、毛巾织机、特种织机、针织圆机、无缝内衣机、袜机、非织造布设备等系列的上百种产品，能够为行业提供纺纱、前准备、织造、非织造四大解决方案，涉及纺织行业的各个领域。产品遍及全国各地，并销往全球30多个国家和地区，在各个行业的市场占有率位居前列。

日发纺机正致力于创造崭新的“数字科技”理念，在未来的整机生产中，建立“人流、物流、信息流”的互动平台，实现科技、环境、制造的和谐统一。铸就“信息化、敏捷化、国际化”的机械制造生产基地。

安徽日发纺织机械有限公司系日发纺机全资子公司，注册成立于2013年，位于马鞍山承接产业转移示范园区内。公司主要产品为清梳联、并条机、转杯纺纱机，继承日发纺机二十多年的专业经验使安徽日发纺机成长为高端纺纱装备研发制造基地。



About Us

Zhejiang Rifa textile machinery co., ltd. is founded in 2002 with a registered capital of 69.487 million yuan. The company is a China national key high-tech enterprises, a key enterprise of the China national machinery industry, a demonstration enterprise of both China national 863 program CIMS engineering and China national CAD application engineering, a China national torch plan high-tech enterprise, and a vice president unit of China textile machinery association. It now holds three subsidiaries: Shandong Rifa textile machinery co., ltd., Anhui Rifa textile machinery co., ltd. And Zhejiang Rifa textile machinery tech co., ltd.

With the vision of “become an agile and international company” and the mission of “Provide users with intelligent textile equipment system solutions, and help users gradually realize the dream of a digital factory”, Zhejiang Rifa Textile Machinery Co., Ltd. is devoted to the area of “digital technology” in mechanical and electrical industry, and has become a well-known textile equipment manufacturer with excellent reputation at home and abroad. For over twenty years, the company has successfully developed four solutions such as spinning, fibre preparation, weaving and non-woven, including blow-room machine, draw frame, rotor spinning machine, air jet vortex spinning machine, two-for-one twister machine, twister machine for tire cord, false-twist texturing machine, precise winding machine(precise rewinding machine), automatic warp drawing machine, air jet loom, water jet loom, rapier loom, terry towel loom, specific loom, circular knitting machine, seamless knitting machine, hosiery machine and non-woven equipment etc hundreds of machines. These products have been distributed to all areas around China and sold to more than 30 foreign countries and regions with a leading market share in each respective industry.

RIFA is devoting itself to create a whole new theory of digital technology, establishing an interactive platform of “people flow, material flow and information flow”, realizing harmony and unify of science and technology, environment and manufacturing, and aiming to become a manufacturing base of “informatization, agility and internationalization”.

Anhui Rifa Textile Machinery Co., Ltd. is a wholly owned subsidiary of Zhejiang Rifa Textile Machinery Co., Ltd., it is founded in 2013, located in Ma'anshan City. The leading products are blow-room machine, draw frame, rotor spinning machine, succeeding above 20 year professional experience from zhejiang Rifa, anhui Rifa has grown to a top grade spinning research and manufacturing base.



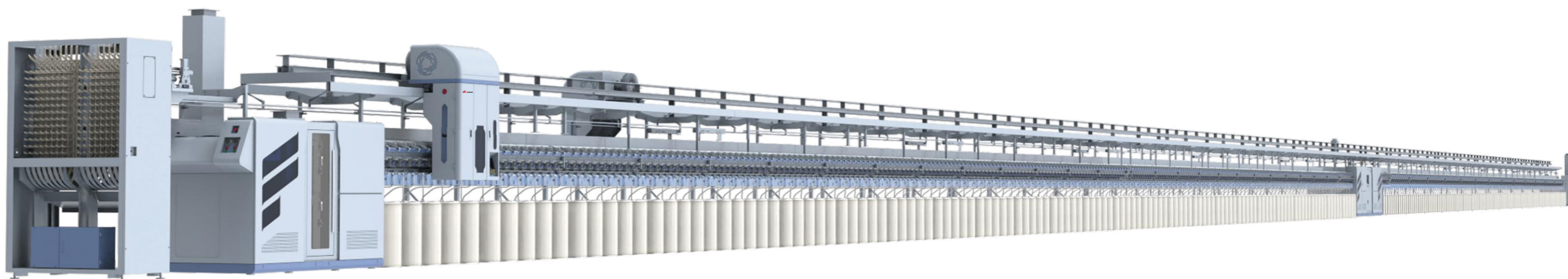

日发纺机自2002年推出第一代转杯纺纱机RFRS10, 累计销售超过1000000锭, 客户家数超过1000家。不断累积的工艺数据与对纺纱技术的研究, 我们洞悉行业的发展趋势与客户需求, 推出节能、高效、智能的全新一代转杯纺机RFRS51。

Since the launching of the first generation of rotor spinning machine RFRS10 in 2002, the cumulative sales of RIFA Spinning machine have exceeded 1,000,000 spindles, and the number of clients has exceeded 1000. Through continuous accumulation of process data and research on spinning technology, we have gained insights on the development trend of the industry and customer needs thoroughly, and hereby introduce the new generation of rotor spinning machine RFRS51 featured at energy saving, high efficiency and intelligence.

转杯纺纱机
ROTOR SPINNING MACHINE

数字化接头
专有的数字化接头模型，保证接头强力和形态。

Digital piecing
Proprietary digital piecing model, to ensure piecing strength and shape.

自动化
RSAJ10小车让纱筒管理更加简单。

Automation
Automatic Doffing&Piecing robots allows bobbin management easier.

灵活性
一台设备最多可同时生产4个品种。

Flexibility
One machine can produce up to 4 varieties at the same time.

高产能
整机头数可达1000锭，引纱速度高达300米/分钟

High capacity
The machine max head can reach 1000 spindles and the yarn guiding speed max can get 300m/min.

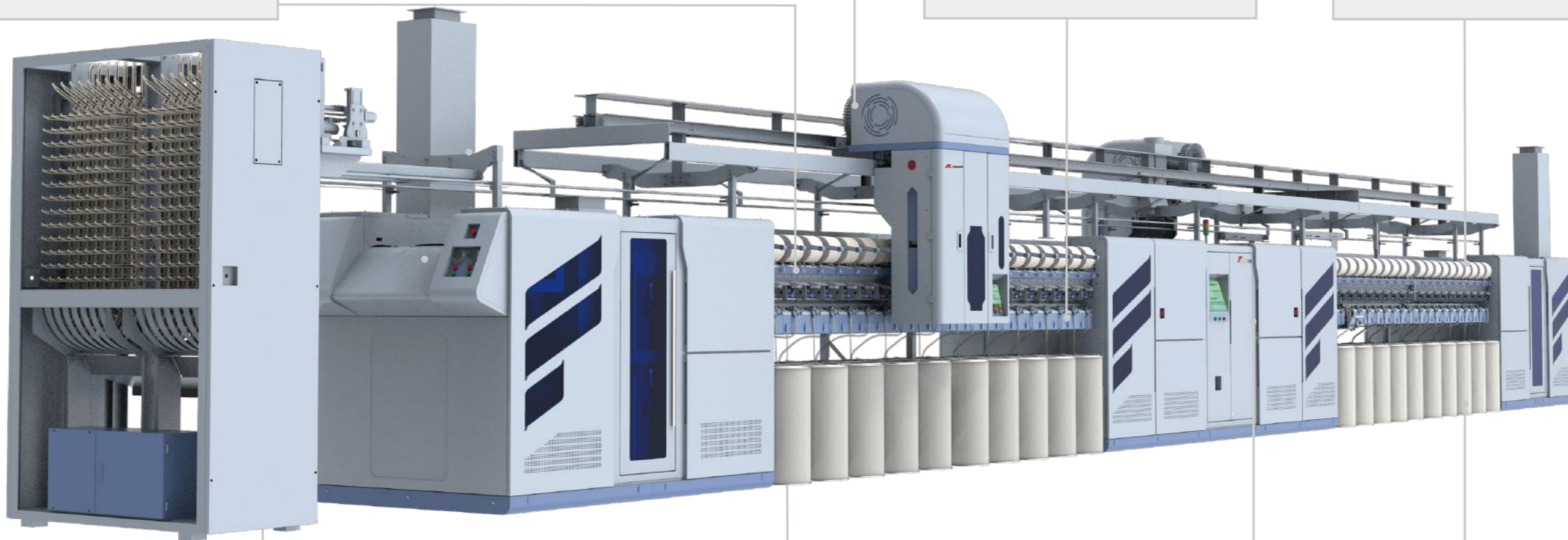

大容量
筒管库最多可容纳528个纸管

High capacity
The bobbin warehouse can hold up to 528 paper tubes.

高速转杯驱动
可选配磁悬浮电机，理论速度可达150000 r/ min。

High speed rotor drive
Magnetic suspension motor is optional, with the theoretical speed up to 150000 r/ min.

大触摸屏界面
提供更加便捷和直观的操作信息化体验。

Large touch screen interface
Provide more convenient and intuitive operation information experience.

合理布局
符合人体工学的操作高度，可选配1200mm条筒，减少挡车工劳动强度。

Reasonable layout
Ergonomic operation height, cylinder height is 1200mm, to reduce the labor intensity of textile worker.

转杯纺纱机

ROTOR SPINNING MACHINE

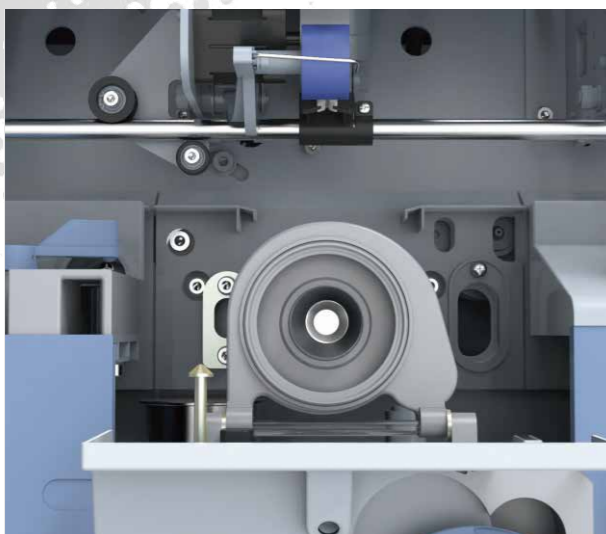

纺纱器 — 转杯纺的心脏

充分实验数据的采集与分析,对纺纱器通道进行优化,使适纺性与成纱质量达到完美结合。获得专利排杂系统,适应更广的原料,使客户从容面对市场变化,并减少工人劳动强度。通道口镶嵌高强度陶瓷,减少纤维对腔体的磨损,延长使用寿命。

Spin box — heart of rotor spinning

Through comprehensive collection and analysis of experimental data, we optimize the channel of spin box to realize a perfect combination between optimal spinning and yarn quality; equipped with patent trash-removal system, it can be used to process a wider range of raw materials, allowing the customers to face the market changes more leisurely and reduce the labor intensity of workers; The opening of channel is embedded with high-strength ceramics, which can reduce the wear-and-tear of fiber to cavity and extend the service life.

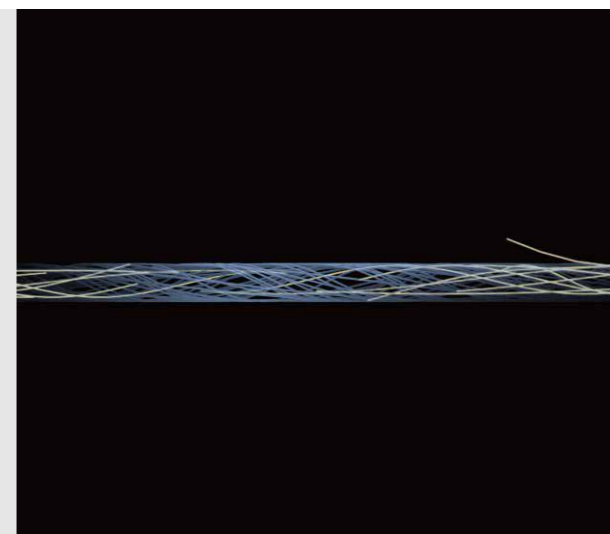

数字接头技术 — 高速纺纱的保证

标配气动抬升装置,断头响应时间仅为0.1秒,经过上百万次试验,可靠性高。独有的接头系统,接头时在皮辊和引纱罗拉作用下握持后再进行储纱,避免纱筒大小对接头质量的影响。专有的接头数学模型与步进罗拉给棉、引纱罗拉引纱,精确控制给棉量、给棉时间和种纱长度,保证接头强力、形态和成功率。同等情况对比,接头强力比原接头强力提高10%。

Digital joint technology — guarantee of high speed spinning

Equipped with pneumatic lifting device as standard configuration, with broken end response time only 0.1 second; After millions of tests, it has high reliability. The unique joint system can store yarn after holding under the action of the roller and the guiding roller, so as to avoid the influence of the bobbin size on the joint quality. The special mathematical model of the joint and the step roller for sliver feeding and yarn guiding can precisely control the sliver feeding amount, sliver feeding time and yarn length to ensure the strength, shape and success rate of the joint. Under the same conditions, the strength of the joint is 10% higher than that of the original joint.



RSAJ10小车 — 强大的自动化能力

强大的自动化能力,将转杯纺的落纱、换纸管、清洁转杯、接头这些工序全部被机械手代替,进一步解放劳动力,为实现关灯工厂再迈一大步。

Automatic Doffing & Piecing robots — powerful automation ability

With powerful automation ability, the doffing, paper tube changing, cup cleaning and joint processes of rotor spinning are all replaced by manipulators, which further liberates labor force and takes a big step for the realization of automatic factory.

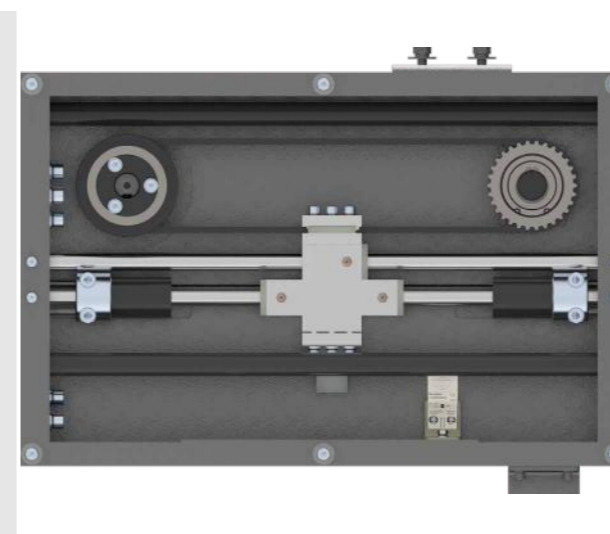

细节优化 — 所求完美

伺服驱动横动导纱,引纱速度达到300米/分。步进驱动微动机构,减少纱线对皮辊的磨损。优化的机架,减少操作高度,可配最高1200毫米的条筒。全机变频驱动,节能降耗;分开独立传动,减少生产辅助时间。

Optimize the details to pursue perfection

Servo drives transverse yarn guiding, with the delivering speed up to 300m/min; Stepping-driven inching mechanism to reduce the wear-and-tear of yarn to the roller; Optimized machine frame to reduce operating height, supporting can of 1200mm at most; Variable frequency drive of the whole machine to realize energy-saving effect; Separate independent transmission to reduce auxiliary time in production.



全车色系改变

色系全部由意大利公司重新设计,色系相比现在将更加丰富与层次感,也会为客户带来全新的视觉冲击。

Color Change of Whole Machine

The color system of machine is redesigned completely by Italian company. Compared with present design, the color system turns to be more abundant with a sense of layering, and brings new visual impact to user.

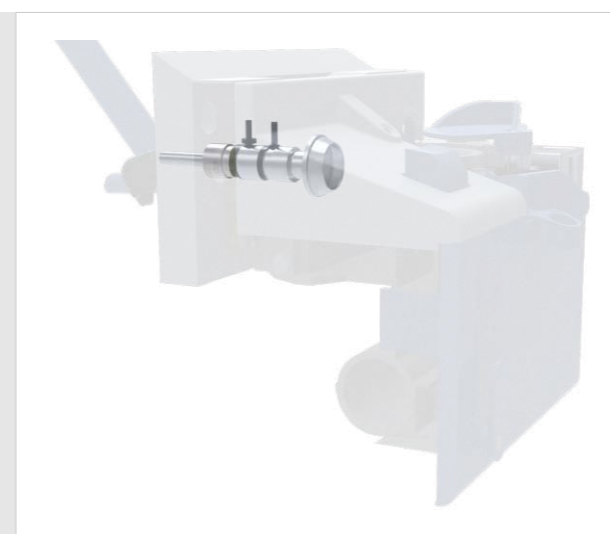

转杯轴承免拆装装置

该装置大大降低保全工的劳动强度,保证隔距稳定性,提高了产品一致性和产量。

Rotor bearing assembly free device

The device reduces the labor intensity of maintenance work significantly, ensures the stability of space distance, and improves product consistency.



集体生头系统

该系统主要用于正常停机或者非正常电网断电停机情况的自动生头,可以减少整机接头时间,降低挡车工劳动强度。

Collective joint System after power off

The system is mainly used for automatic joint under conditions of normal shutdown or abnormal grid power failure, which can reduce the joint time of the whole machine, reduce the labor intensity of worker.



健康互联网系统

客户主机程序可进行在线升级、可对客户主要传动部件进行在线监测与预警、客户可在全球各地实时了解自己设备的实际运行情况。

Health Internet System

Host program of machine can be upgraded online, support-functions of online monitoring and early warning towards-main transmission components, and clients can get the actual operation of equipment in real time at any places-around the world.



正压散热系统

该系统可以减少飞花、粉尘在车头车尾内腔聚集,降低保全工的劳动强度,改善了电气元件的散热条件,从而增加了机台运行的稳定性,降低了能耗。

Positive Pressure Cooling System

The system can reduce the accumulation of flying and dust in the inner cavity of headstock and tail box, reduce the laborintensity of maintenance workers, improve the heat cooling condition of electrical components, and thereby increase the operation stability and reduce energy consumption.

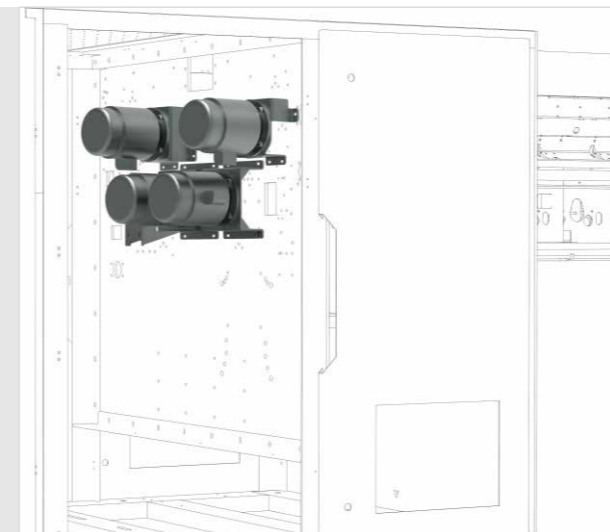

电子张力系统

采用数码控制,可以减少复杂的机械调节工作,客户可直接在车头显示屏上进行张力系数调节,调节精度可达0.001,保障了纱锭成型稳定。

lectronic Tension Systemage

The digital control mode can reduce the work of complicated mechanical adjustments. The user can adjust the tension coefficient directly on the screen of headstock, with the adjustment precision up to 0.001, which ensures stable forming of winding package.



集成控制

采用分布式控制,响应速度快,信号直观,操作方便,维护便捷。

Integrated control

Distributed control, fast response, intuitive signal, easy operation and maintenance



全球采购 — 品质保证

与知名供应商开展战略合作,专件全球采购,保证设备品质,完善的品管系统,确保产品质量。

Global Sourcing to Guarantee Quality

We carry out strategic cooperation with well-known suppliers, with special components purchased via global sourcing to ensure equipment quality. Perfect and sound quality management system ensures product quality.

转杯纺纱机
ROTOR SPINNING MACHINE

外形尺寸图 Machine Dimension Drawing

长度信息 Machine Length

- L=机器的总长 Machine length
- N=中段数目 No.of section
- $L=2942mm+2380mm*N+3663mm$ ($0 < N \leq 30$)

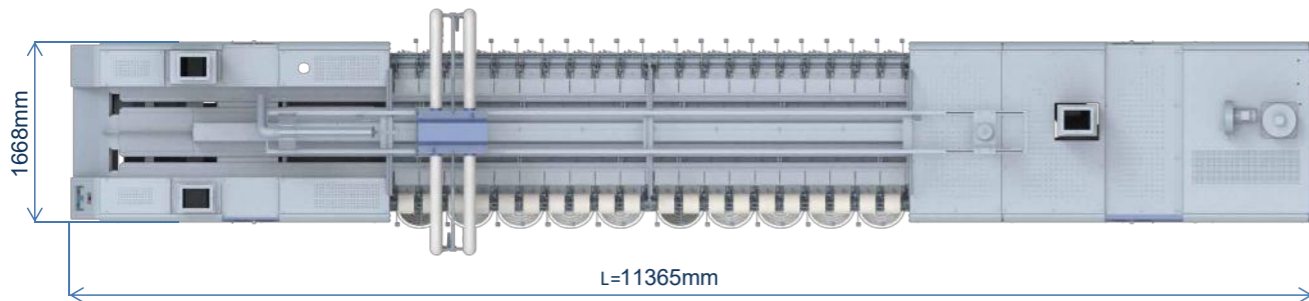
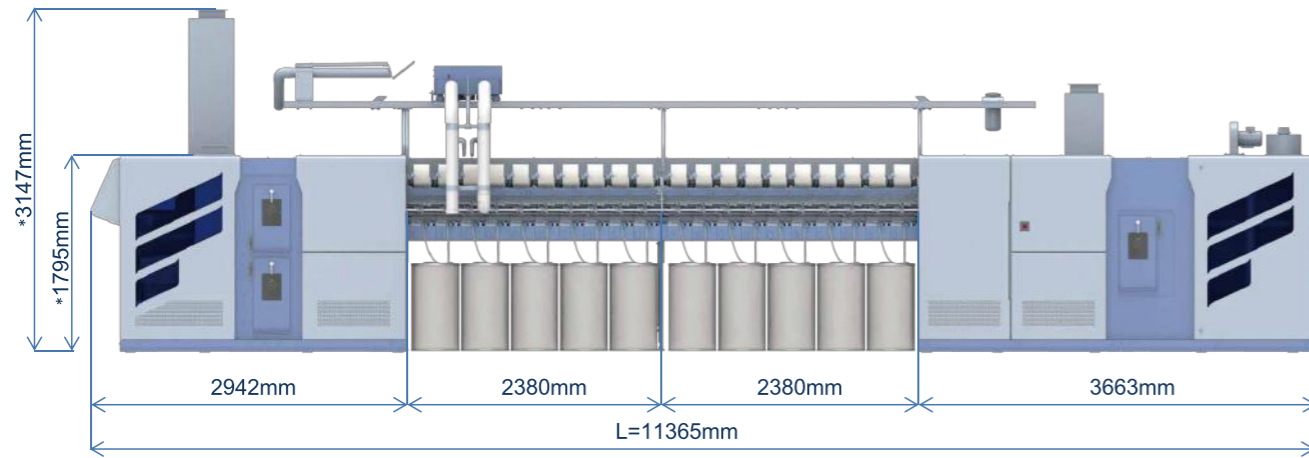

长度信息 Machine Length

- L=机器的总长 Machine length
- N=中段数目 No.of section
- L1 (筒管库)=750mm+1390mm
- L2 (整机)=2942mm*2+2380mm*N+4813mm ($30 < N \leq 50$)
- L=L1+L2

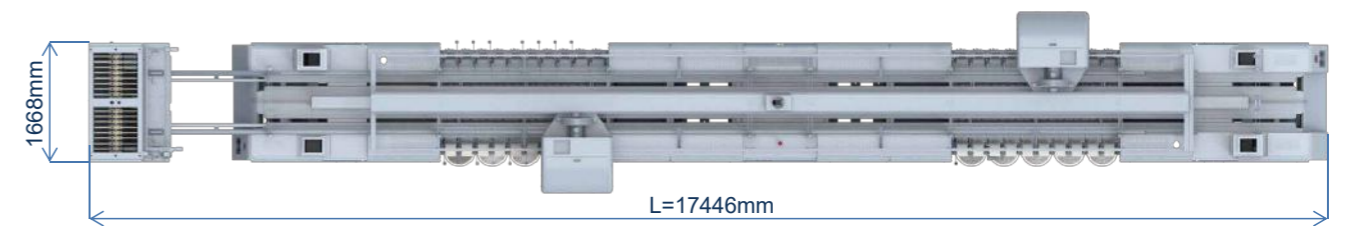
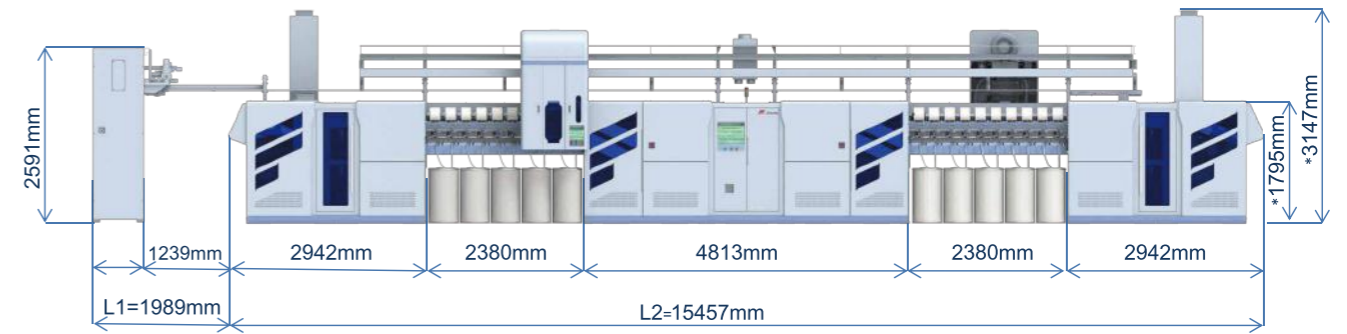

技术规格
SPECIFICATION

项 目	单 位	技术指标
转杯转速	r/min	45000-150000分开独立传动变频调节, 两种传动方式可供选择
引纱速度	m/min	最高300
导纱角	度	30°-42°无级调节
分梳辊转速	r/min	6000-10000双面独立传动, 变频调节
抽气风机排气量	m³/h	≤27000, 变频器调节
纱线支数	tex(Ne)	120-15(5-40) 随锭数变化
纤维长度	mm	≤60mm
牵伸倍数	倍	20-280
捻度范围	t/m	200-2000
喂入条子	ktex	2.5-7
张力牵伸倍数	倍	0.6-1.5
分梳辊直径	mm	65
转杯直径	mm	32/34/36/40/50/54
锭距	mm	230
总锭数	锭	≤1000
1节中段的锭数	锭	20
平筒纱管规格 (内径×长度)	mm	Φ42 (卷边) /54 (直边) Φ40 (卷边) /50 (直边)
锥筒纱管规格 (内径×长度)	mm	2°Φ44 (卷边) /65 (直边)
条筒规格 (外径/高度)	mm	16" (Φ400) 、 18" (Φ450) 、 20" (Φ530) / 标准高度900, 可选1200
卷装规格 (直径)	mm	平筒 最大Φ300 锥筒 最大Φ270
满筒纱的重量	kg	最大4
抬臂装置		气动自动抬升
机器长度	m	≤129.5
机器重量	kg	头+N节中段+尾 (N≤50) 4000+800*N+3100*2
最大装机容量	kw	352

Item	Unit	Technical Indicators
Rotor Speed	RPM	45000-15000 separate independent transmission and drive, Inverter adjustment, two transmission mode can be choice.
Deliverg Speed	m/min	Max. 300
Guiding Angle	Degree	30° - 42° stepless regulation
Opening Roller Speed	r/min	6000-10000 two-side independent drive , Inverter adjustment
Exhaust Volume	m³/h	≤27000, Inverter adjustment
Yarn Counts	tex(Ne)	120-15(5-40) Follow spindles no. change
Fiber Length	mm	≤60mm
Draft Multiple	Times	20-280
Twist Range	t/m	200-2000
Sliver weight	tex	2.5-7
Tension Draft Multiple	Times	0.6-1.5
Diameter of Opening Roller	mm	65
Diameter of rotor	mm	32/34/36/40/50/54
Spindle gauge	mm	230
Rotor No.	Spindle	≤1000
Rotor No. of one section	Spindle	20
Specification of Flat Bobbin (Inner Diameter × Length)	mm	Φ42(Rolling edge)/54(Straight edge) Φ40(Rolling edge)/50(Straight edge)
Specification of Conical Cone (Inner Diameter × Length)	mm	2°Φ44(Rolling edge)/65(Straight edge)
Specification of Sliver Can (Outer Diameter / Height)	mm	16"(Φ400), 18"(Φ450), 20"(Φ530)/ standard height of 900, 1200 optimal
Specification of Package (Diameter)	mm	Max. Φ300 for flat bobbin; Max. Φ270 for conical cone.
Weight of Full Bobbin	kg	Max. 4
Lifting Device		Automatic air lifting
Length of Machine	m	≤129.5
Weight of Machine	kg	Head+ the sections(N means section number)+ Tail (N≤50) 4000+800*N+3100*2(N bigger than 30 then have two tails)
Maximum Installed Power	kw	352